

TRANSISTOR (NPN)

FEATURES

- Complementary to MMBT3906

SOT-23

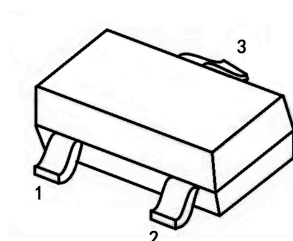

1: B
2: E
3: C

CIRCUIT DIAGRAM

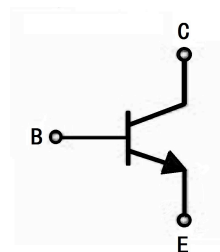

MARKING : 1AM

MAXIMUM RATINGS (Ta=25°C unless otherwise noted)

Parameter	Symbol	Value	Unit
Collector-Base Voltage	V_{CBO}	50	V
Collector-Emitter Voltage	V_{CEO}	45	V
Emitter-Base Voltage	V_{EBO}	5	V
Collector Current	I_{CM}	0.1	A
Power Dissipation	P_D	0.45	W
Junction Temperature	T_J	150	°C
Storage Temperature	T_{stg}	-55~150	°C

ELECTRICAL CHARACTERISTICS (Ta=25°C unless otherwise spspecified)

Parameter	Symbol	Test conditions	Min	Max	Unit
Emitter-base breakdown voltage	BV_{EBO}	$I_E=100\mu A, I_C=0$	5		V
Collector-base breakdown voltage	BV_{CBO}	$I_C=100\mu A, I_E=0$	50		V
Collector-emitter breakdown voltage	BV_{CEO}	$I_C=100\mu A, I_B=0$	45		V
Emitter cut-off current	I_{EBO}	$V_{EB}=5V, I_C=0$		0.1	μA
Collector cut-off current	I_{CBO}	$V_{CB}=50V, I_E=0$		0.1	μA
Collector cut-off current	I_{CEO}	$V_{CE}=45V, I_B=0$		0.1	μA
Collector-emitter saturation voltage	V_{CESAT}	$I_C=100mA, I_B=5mA$		0.3	V
Base-emitter saturation voltage	V_{BESAT}	$I_C=100mA, I_B=5mA$		1.1	V
DC current gain	h_{FE}	$V_{CE}=5V, I_C=1mA$	100	300	
Transition frequency	f_T	$V_{CE}=5V, I_C=10mA$ $F=30MHZ$	150		MHZ

TYPICAL CHARACTERISTICS

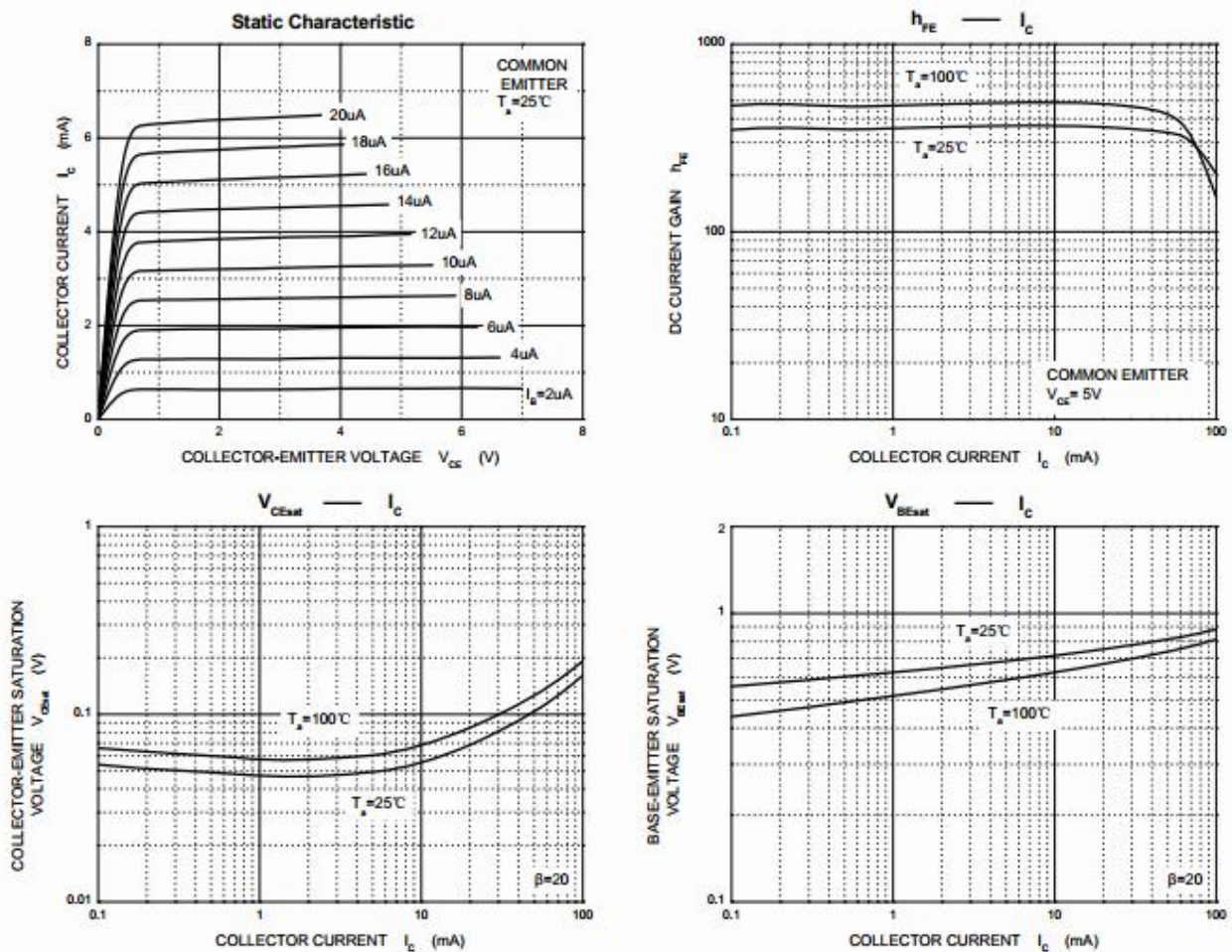

SOT-23 PACKAGE OUTLINE DRAWING

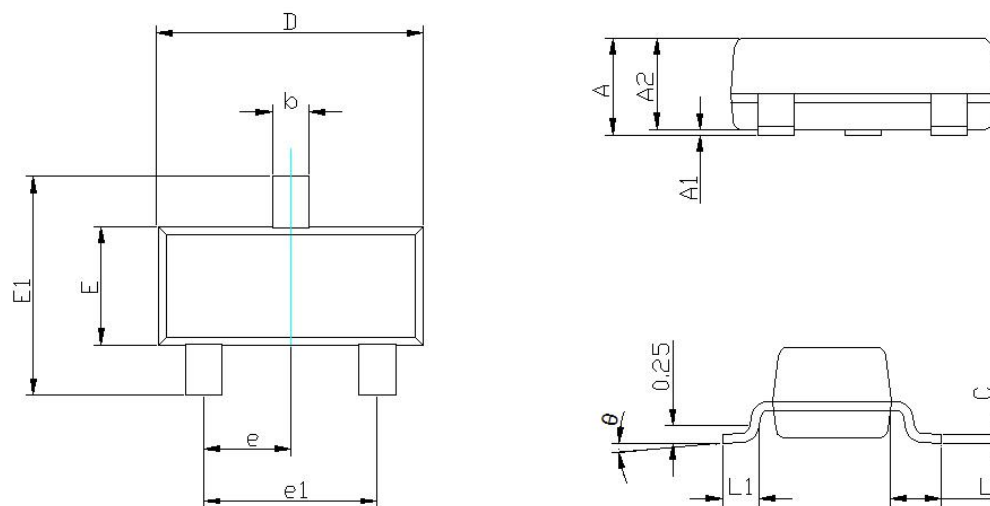

SYMBOL	MILLIMETERS		INCHES	
	MIN	MAX	MIN	MAX
A	0.900	1.15	0.035	0.045
A1	0.000	0.125	0.000	0.005
A2	0.900	1.050	0.035	0.041
b	0.300	0.500	0.012	0.020
c	0.080	0.150	0.003	0.006
D	2.800	3.000	0.110	0.118
E	1.200	1.400	0.047	0.055
E1	2.250	2.550	0.089	0.100
e	0.950TYP		0.037TYP	
e1	1.800	2.000	0.071	0.079
L	0.550REF (0.4-0.6)		0.022REF (0.016-0.024)	
L1	0.300	0.500	0.012	0.020
θ	0°	8°	0°	8°